

# SPARE PARTS SECTION

## SAND BLAST CABINET

**Model. SB-375**

Order Code S300

*Edition No : SB-375-1*

*Date of Issue : 08/2022*

The following section covers the spare parts diagrams and lists that were current at the time this manual was originally printed. Due to continuous improvements of the machine, changes may be made at any time without notification.

### HOW TO ORDER SPARE PARTS

1. Have your machines model number, serial number & date of manufacture on hand, these can be found on the specification plate mounted on the machine
2. A scanned copy of your parts list/diagram with required spare part/s identified.

**NOTE: SOME PARTS MAY ONLY BE AVAILABLE AS AN ASSEMBLY**

3. Go to [www.machineryhouse.com.au/contactus](http://www.machineryhouse.com.au/contactus) and fill out the inquiry form attaching a copy of scanned parts list.



## WARNING

*Always disconnect the power to the machine before servicing or doing maintenance to the machine.*

**SPARE PARTS DIAGRAM**

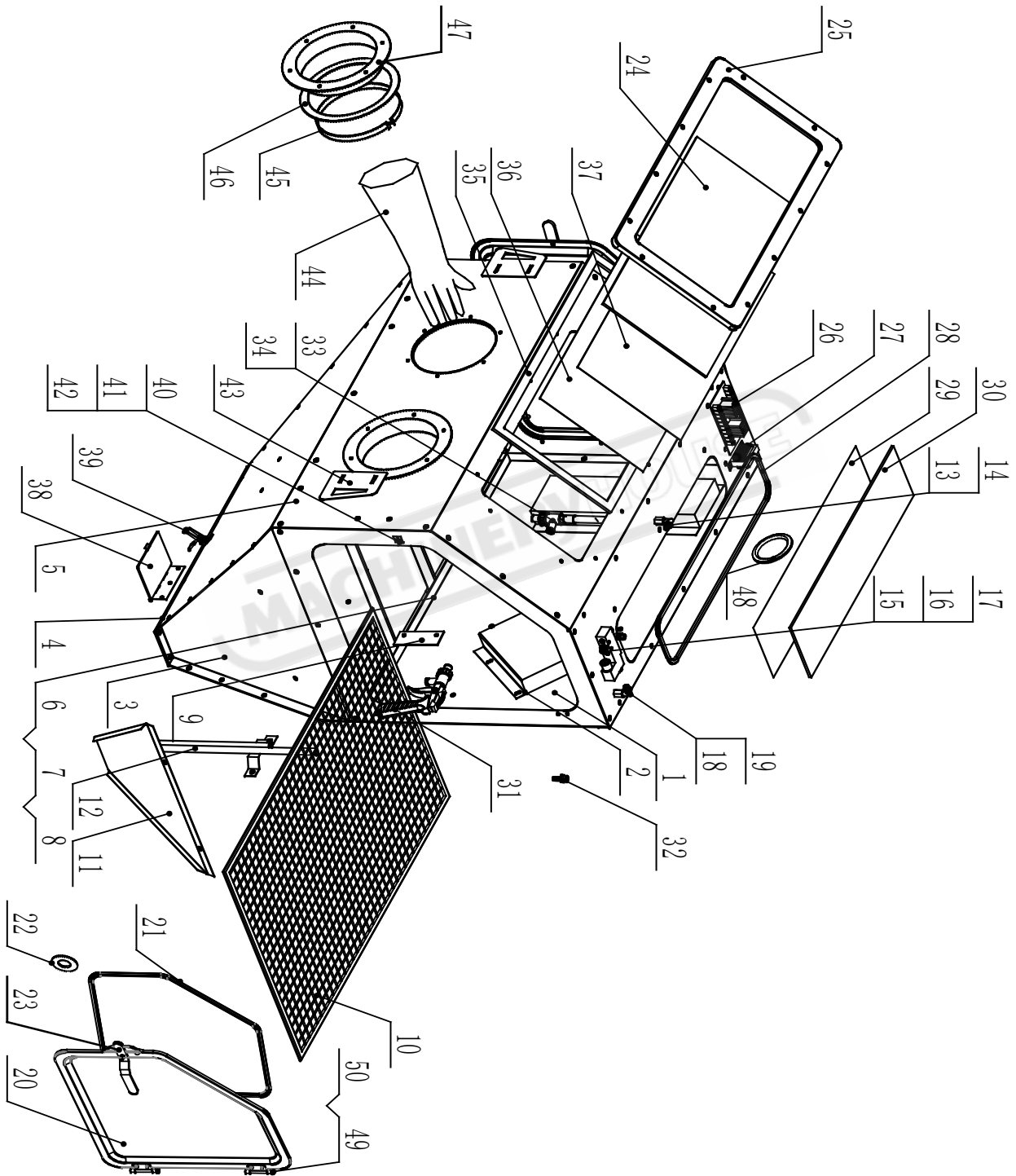

**SPARE PARTS LIST**

Item	DESCRIPTION	Size	Qty
1	Backboard Of Cabinet		1
2	Sand Protection Plate		2
3	Welded Left Board Asseby Of Cabinet		1
	Welded Right Board Asseby Of Cabinet		1
4	Bottom Plate Of Cabinet		1
5	Front Panel Of Cabinet		1
6	Support Board I	L=885	2
7	Web Support Board Ii	L=458	2
8	Support Boart Iii		3
9	Connecting Plate Of Lock Block		2
10	Web		1
11	Left Inside Support Plate Of Funnel		1
	Right Inside Support Plate Of Funnel		1
12	Abrasive Suction Pipe Assembly		2
13	Female Coupling(L=25)	G1/4"	1
14	L Quick Change Coupling	G1/4" Ø8	1
15	Solenoid Valve	4V210-08-DC12V-4.8W	1
16	Quick Change Coupling	G1/4" Ø8	1
17	L-Quick Change Coupling	G1/4" Ø8	1
18	L-Quick Change Coupling	G1/4" Ø8	1
19	Female Coupling(L=25)	G1/4"	1
20	Left Door Assembly		1
	Right Door Assembly		1
21	Rubber Seal	L=1860	2
22	Flat Washer	Ø6* Ø 30*2.0	2
23	Latch		2
24	Organic Glass	616*300*1.5	1
25	Window Frame		1
26	Contral Board		1
27	Transformer	220~240V-AC15V-1.2A	1
28	Rubber Seal	L=1475	1
29	Pe Film	560*90*0.15	6
30	Glass	610*300*5.0	1
31	Sand Gun Assembly	G1/4-19	1
32	Ø7.8 End Adaptor	Ø7.8	1
33	Flexible Pipe(Double Thhread)	L=300 G1/4	1
34	Auto-Nozzle Assembly		1
35	Window Washer	Ø3.0*22	1
36	Pe Film	548*250*0.15(220)	6
37	Glass	610*300*5.0	1
38	Cover Of Funnel		1
39	Lock Parts Assembly		1
40	Proximity Switch		2
41	Switch Cover		2
42	Cord Grip		17
43	Door Lock		2
44	Gloves	L=600 (SBC220.350.420.990.1200)	1
45	Gloves Grip Assembly		2
46	Washer For Golves Seat		2
47	Gloves Seat		2
48	Protection Ring For Inlet Hole	10	1
49	Door Hinge Pin		4
50	Door Hinge		4

**SPARE PARTS LIST**

Item	DESCRIPTION	Size	Qty
51	CROSS HEAD SCREW	M6*12	
52	HEX NUT	M6	
53	CLAMP	Ø12 - Ø13	
54	CLAMP	Ø 22	
55	PVC HOSE	Ø13* Ø19*100000	
56	PVC HOSE	Ø6.2*2	
57	HEX NUT	M6	
58	SEAL SPONGE	6.0*21	
59	CROSS HEAD SCREW	M3*25	
60	HEX NUT	M3	
61	SUNK CROSS SCREW	M4*8	
62	SUNK CROSS SCREW	M4*25	
63	SUNK CROSS SCREW	M4*30	
64	SUNK CROSS SCREW	M4*20	
65	SPRING WASHER	M4	
66	HEX NUT	M4	

**NEW DOOR DESIGN**

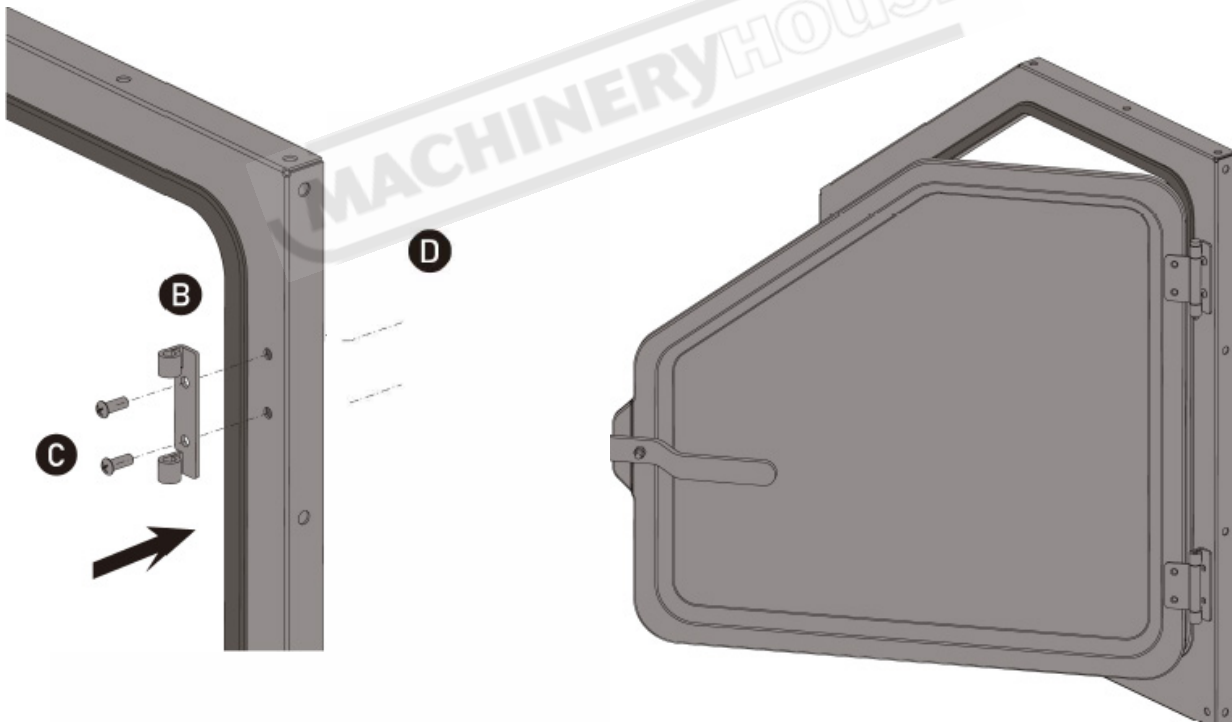

ELECTRICAL DIAGRAM

